



POWDERLINER II

TIPPABLE POWDER TANKER!



www.benalu.com - facebook : benalu - youtube : benalu constructeur



Type: Tanker

Chassis: aluminium

Box: aluminium

Height: 4m

Volume: from 50 to 65 m³

Usage: food, minerals, chemicals

Weight: from 6000 kg



- **Wider main beam distance** and “J” structure for the best stability on the market
- **Straight rear** part that offers a gain of volume, of ground clearance and an improvement of the overhang
- **XL welded and bolted supports** to the chassis improve overall stability
- **Diameter of tank at 2550mm:** Optimized volume!
- **Rear landing legs** for stabilization

OPTIONS DESIGNED FOR OPTIMUM USAGE!

- Specific device for the transport of food, chemical or mineral products
- Dumping unit, case and flexible door for ease of use
- Breakwater equipment specific for transporting liquid fertiliser
- Unlimited choice of colours and configurations
- etc.

Examine the various available options on www.benalu.com



POWDERLINER II

TIPPABLE POWDER TANKER!



www.benalu.com - facebook : benalu - youtube : benalu constructeur

TECHNICAL SPECIFICATIONS



"J" chassis

Exclusive BENALU

Improved axle centre distance and structure providing the best stability on the market.



Straight rear part

Straight rear part that offers a gain of volume, of ground clearance and an improvement of the overhang



100% aluminium tanker

Aluminium tank on reinforced bases of 2550mm diameter.



Stabilising struts

Individual pneumatic control stabilising struts that provide unloading stability.



Anti-slip strips

Large non-slip strips placed on each side of the manholes.

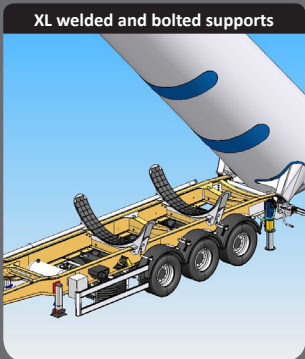

XL welded and bolted supports

XL welded and bolted supports to the chassis improve overall stability



Case

Aluminium watertight base with large capacity (800x800)
Range of different accessories (connectors, cones etc.)

OPTIONS & VARIANTS

Specific equipment: food, chemicals and minerals



Various pieces of equipment specific to each type of transport (valves, filters etc.)



Tipping unit

Wired control system supplied with a 20-metre cable.



100% aluminium chassis
Version with improved centre distance between axles and "J" structure!

Rue Fresnel - BP 10002 - 62801 LIEVIN Cedex - France

E-MAIL : contact@benalu.com

WEBSITE : www.benalu.com

FACTORY : Tel. +33 (0)3 21 79 43 00

REPAIRS : Tel. +33 (0)3 21 79 43 70

SPARE PARTS: Tel. +33 (0)3 21 79 43 33